



SINTEF Building and Infrastructure
P.O.Box 124 Blindern
N-0314 Oslo
Tel. 47 22 96 55 55
Fax 47 22 69 54 38TAB



European Technical Assessment

ETA-08/0285
of 07.03.2014

General Part

Technical Assessment Body issuing the ETA:
SINTEF Building and Infrastructure

Trade name of the construction product	Guardian Fastening System
Product family to which the construction product belongs	Fasteners for mechanically fastened flexible roof waterproofing systems
Manufacturer	AFAST Holding BV Grasbeemd 14 5705 DG Helmond The Netherlands
Manufacturing plant(s)	AFAST Holding BV Grasbeemd 14 5705 DG Helmond The Netherlands
This European Technical Assessment contains	16 pages including 2 Annexes which form an integral part of this assessment
This European Technical Assessment is issued in accordance with regulation (EU) No 305/2011, on the basis of	ETAG No. 006 edition March 2000, Amended November 2012, used as European Assessment Document (EAD)
This version replaces	ETA-08/0285 issued on 11.11.2008

Translations of this European Technical Assessment in other languages shall fully correspond to the original issued document and should be identified as such.

Communication of this European Technical Assessment, including transmission by electronic means, shall be in full (excepted the confidential Annex(es) referred to above). However, partial reproduction may be made, with the written consent of the issuing Technical Assessment Body. Any partial reproduction has to be identified as such.

1. Technical description of the product and intended use

Guardian Fastening System is used as mechanical fastening of insulation, bitumen based multi layer or single ply waterproofing membranes, or polymeric single ply waterproofing membranes, for flat roofing. The supporting roof structure may be of steel, concrete, light weight concrete or wood as defined in ETA Guideline No. 006 edition March 2000, amended November 2012. For Systems of mechanically fastened flexible roof waterproofing membranes, paragraph 2.2 iii.

The range of fasteners consists of washers, washers with integrated sleeve, screws, nails, and plugs as illustrated in Annex 1. Guardian Fastening System also consists of GuardianWeld & Centrix electro bonding system which is used to bond special adhesive coated metal fixing plates to single-ply waterproofing membranes, see ch. 4.2.

The fastener system is introduced to the market separately from the other components of roof waterproofing membrane kits, and this ETA covers only the performance characteristics of the Guardian Fastening System. A separate ETA according to ETAG 006 is necessary in order to cover an entire kit for mechanically fastened roof waterproofing membranes.

The fasteners may be used for all types of flexible membranes. The supporting roof structure may consist of profiled steel decks, concrete, light weight concrete, or a wood based constructions. The Guardian Fastening System may be used with membranes installed on a thermal insulation material or directly to the supporting roof underlay.

2. Specification of the intended use in accordance with the applicable European Assessment Document (hereinafter EAD)

Installation and design

General

The fasteners must be installed according to the manufacturer's instructions. It is the manufacturer's responsibility to provide correct information about the application of the products to the users.

Fastening with steel washers may on stiff substrates, i.e. on wood-based roof substrate, non compressible insulation or on concrete.

Plastic fasteners with integrated sleeve or step secured steel washers (steel washers together with screws equipped with a separate threading which avoid the washer to be pressed down) are recommended on thermal insulation. The insulation material should have a compressive strength ≥ 60 kPa at 10% deformation according to EN 826.

If there is doubt about the suitability of the substrate, e.g. on a construction site, a pullout test on site should be performed to verify the performance of the fastener (see ETAG 006 Annex C).

Furthermore, care should be taken during design to ensure that bimetallic corrosion between metal parts, especially between substrate and screw, does not occur. Likewise, use of insulation materials containing substances which can affect the performance of the fasteners must be avoided.

Fastening in wood

Minimum thickness for timber based substrate is 18 mm. For timber deck applications a site pull out test is recommended.

Fastening in concrete

When fixing Guardian concrete nails and screws the drill hole diameter must be 5 mm. The drill hole depth should be minimum 30 mm, unless special precautions are taken regarding installation control and inspection. Minimum anchorage depth shall be minimum 20 mm. Fixings in 40 mm thick

concrete without penetration requires drilling with depth control. Concrete compression strength is minimum class C25 according to EN 206-1.

Fastening in light weight concrete

When fixing Guardian Light Weight Concrete Screw LBS 8.0 and LBS 6.0 in aerated concrete, the anchoring depth must be minimum 65 mm. Pullout tests are always recommended in light weight concrete.

Fastening in metal decks

Load bearing decks made of profiled steel sheets shall have a minimum thickness of 0.7 mm. In particularly exposed areas the recommended minimum thickness is 0.8 mm for fixing roofing membranes to the steel decks.

Fastening with GuardianWeld & Centrix-system

The GuardianWeld & Centrix electro bonding system must be applied according to the manufacturer's user manual. The different types of plates are laminated with special heat activated adhesive for PVC, TPO or EPDM waterproofing membranes.

3. Performance of the product and references to the methods used for its assessment

See Annex 2.

4. Assessment and verification of constancy of performance (hereinafter AVCP) system applied, with reference to its legal base

Mechanical resistance and stability

Not relevant.

Safety in case of fire

No performance determined. The reaction to fire of roof waterproofing kits is determined for the complete kits including the membrane.

Hygiene, health and environment

According to the manufacturer's declaration the screws and washers with corrosion protection contains no chromium 6 compounds. Consequently the products do not contain any dangerous substances according to the EU database.

Safety in use

The fasteners have been tested for wind uplift according to EN-16002:2010 / ETA Guideline No. 006 edition March 2000, amended November 2012. For Systems of mechanically fastened flexible roof waterproofing membranes, paragraph 2.2 iii. Axial pull out performance from substrates and resistance to unwinding are shown in Annex 2. The wind uplift performance of roof waterproofing kits is mainly determined by the roofing membranes. More than 100 full scale wind load tests with bituminous and polymeric membranes have been executed. The membranes are fixed with washers, washers with integrated sleeves and barbed washers in combination with fixings to substrates of steel, wood, concrete and light weight concrete. The complete test reports may be obtained from AFAST Holding BV.

Protection against noise

Not relevant

Energy consumption and heat retention

Not relevant

Aspects of durability

The plastic fasteners produced of polypropylene and polyamide satisfy the aspects of durability according to ETAG 006 ch. 5.3.7, see Annex 2. The Guardian tube washers made of polypropylene and polyamide have an acceptable resistance to brittleness according to ETAG 006 ch. 5.3.4, see Annex 2.

Carbon steel fasteners have a corrosion protection of Chrome 6 free Enduroguard 15[®] coating. Stainless steel fasteners in grade 1:4301/A2 Metal plates in carbon steel are Sendzimir galvanized, min 275 g/m². All metallic components in the Guardian fastening system corresponds to corrosion protection according to ETAG 006 ch.5.3.7,see Annex 2. Test procedure is 15 cycles Kesternich (2l SO₂).

Identification

The characteristic values of detailed product dimensions and respective tolerances are stated in the manufacturer's technical dossier and form a part of the control plan for the factory production control. All fasteners, steel washers and tube washers are marked with the Guardian "G" mark. The marking of tube washers may be combined with the Guardian name or another brand name for products produced under private label. All packaging is to be marked with product type and batch number.

5. Technical details necessary for the implementation of the AVCP system, as provided for in the applicable EAD

According to Decision 98/143/EC by the European Commission, the system 2+ of assessment and verification of constancy of performance applies. See Annex V to Regulation (EU) No. 305/2011.

Issued in Trondheim on 07.03.2014

By

SINTEF Building and Infrastructure



Hans Boye Skogstad
Approval Manager

Annex 1

Description of Guardian Fastening System

Table 1

Fastener type	Fig. no.	Function	Material
GUARDIAN R(P) 45 & HR 45	1	Tube washer	Polypropylene
GUARDIAN RB(P) 48	2	Tube washer with three barbs	Polypropylene
GUARDIAN RBS(P) 50	3	Tube washer with six barbs	Polypropylene
GUARDIAN R(P) 75 & HR 75	4	Tube washer	Polypropylene
GUARDIAN TB(P) 8040	5	Tube washer with two barbs	Polyamide 6.6
GUARDIAN SPC-80-F-4 CT	6	CT Tube washer	Polyamide 6 + Coated & laminated
GUARDIAN SPB 8240-D,S	7	Barbed steel washer	Sendzimir galvanized steel
GUARDIAN SPA 8240-D,F,S	8	Steel washer	Sendzimir galvanized steel
GUARDIAN SPB 50-F/S/D	9	Barbed steel washer	Sendzimir galvanized steel
GUARDIAN SP 50-D,F,S	10	Steel washer	Sendzimir galvanized steel
GUARDIAN SP 70-D,F,S	11	Steel washer	Sendzimir galvanized steel
GUARDIAN SP 40-F,D,LBS	12	Steel washer	Sendzimir galvanized steel
GUARDIAN BN 5.6	13	Concrete nail	Coated carbon steel
GUARDIAN BNRF 5.5	14	Concrete nail	Stainless steel
GUARDIAN ACS-6.1	15	Concrete screw with hexagonal nut	Coated carbon steel
GUARDIAN HD 6.1	16	Concrete/light weight concrete/wood screw	Coated carbon steel
GUARDIAN CS 6.1	17	Concrete screw	Coated carbon steel
GUARDIAN GPR 6.3	18	Peel Rivet	Aluminium body/Galvanized Pin
GUARDIAN LBS 6.0	19	Light weight concrete/wood screw	Coated carbon steel
GUARDIAN LBS 8.0	20	Light weight concrete screw	Coated carbon steel
GUARDIAN BS 4.8	21	Steel deck screw	Coated carbon steel
GUARDIAN BSHD 4.8	22	Steel deck screw	Coated carbon steel
GUARDIAN BS 5.5	23	Steel deck screw	Coated carbon steel
GUARDIAN BS 6.1	24	Steel deck screw	Coated carbon steel
GUARDIAN TS 5.2	25	Timber deck screw	Coated carbon steel
GUARDIAN PS 4.8	26	Steel deck screw	Coated carbon steel
GUARDIAN BSRF 4.8	27	Steel deck screw	Stainless steel
GUARDIAN DBT (A) 4.8	28	Steel deck screw	Coated carbon steel
GUARDIAN DB(A) 4.8	29	Steel deck screw	Coated carbon steel
GUARDIAN CP-8 and CPN-8	30	Concrete plug	Coated steel pin/ Polypropylene
GUARDIAN PP 45	31	Washer with barbs	Polyamide 6

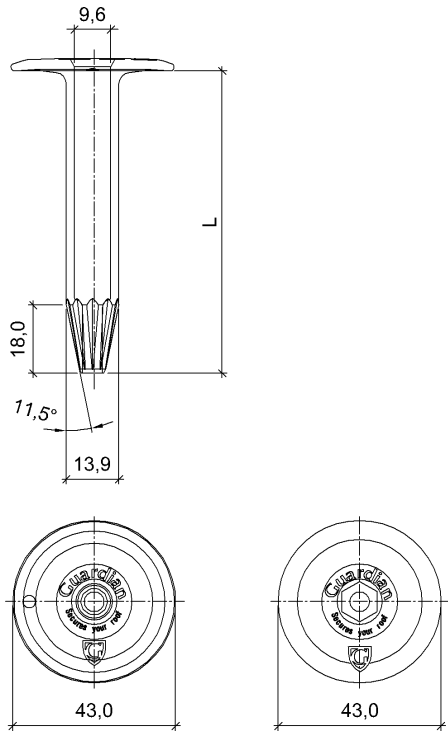

Fig. 1
 Tube w asher R(P) 45
 Tube w asher HR45 w ith hexagonal internal tube
 shape (used together w ith ACS 6.1).

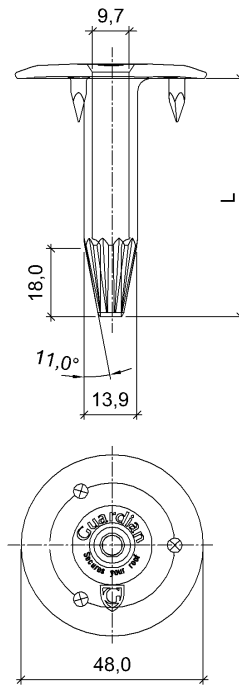

Fig. 2
 Tube w asher RB(P) 48 w ith three barbs

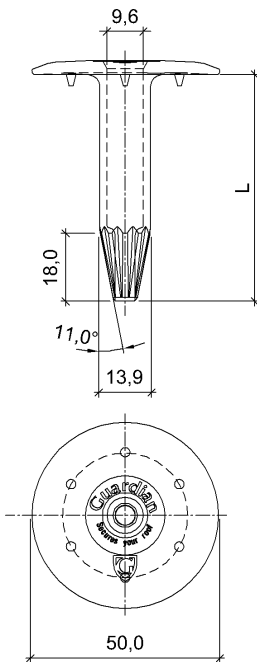

Fig. 3
 Tube w asher RBS(P) 50 w ith six barbs

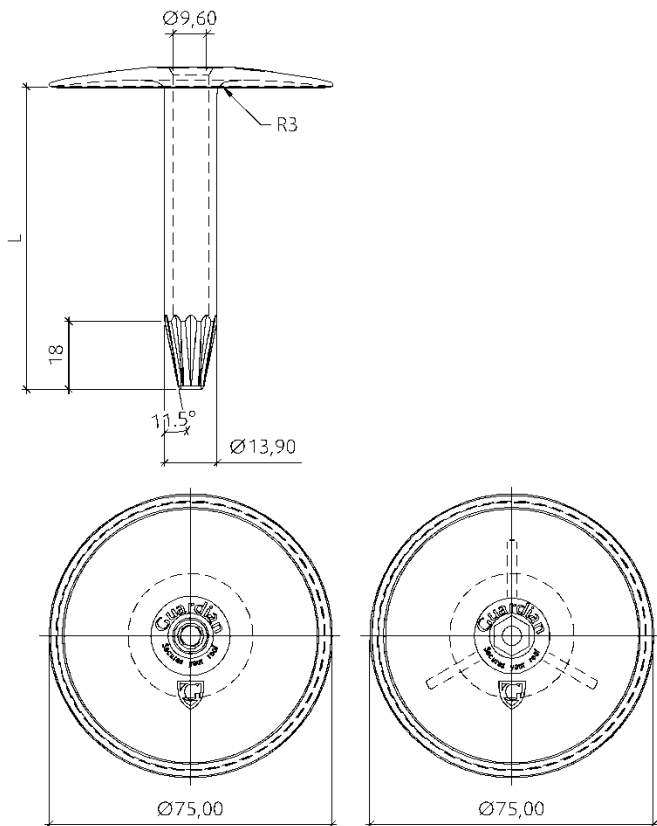

Fig. 4
 Tube w asher R(P) 75 for fixation of insulation, or first layer of bitumen
 in a multi layer system.
 Tube w asher HR75 w ith hexagonal internal tube
 shape (used together w ith ACS 6.1).

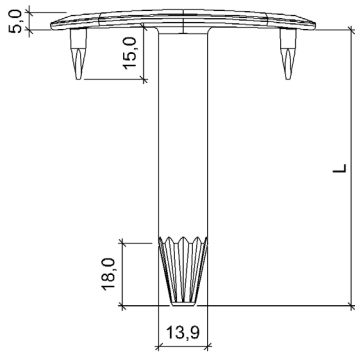

Fig. 5
Tube washer TB(P) 8040 w ith two barsbs

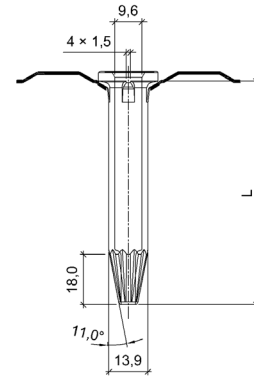
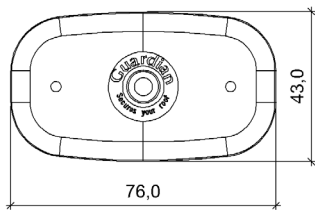

Fig. 6
SPC80-F-4 CT Centrix Tube washer

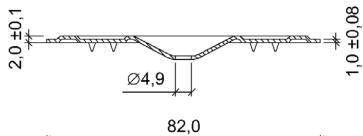
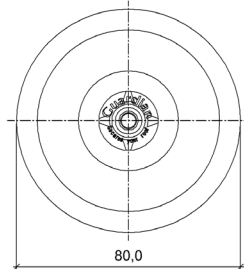

Fig. 7
SPB 8240-D,S Barbed steel w asher

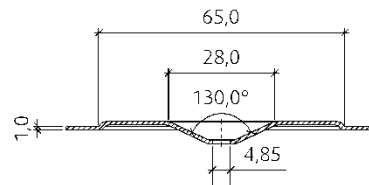
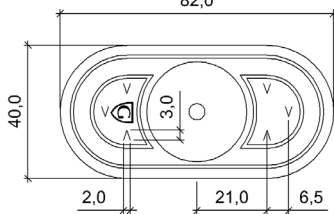

Fig. 8
SPA 8240-D,F,S Steel w asher

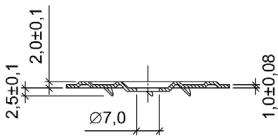
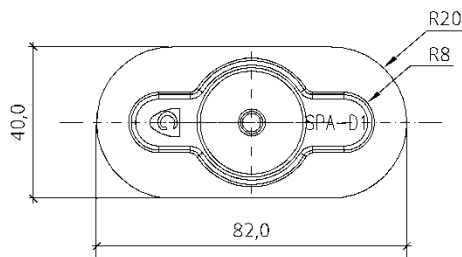

Fig. 9
SPB 50-F/S/D Barbed steel w asher

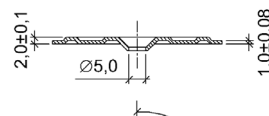
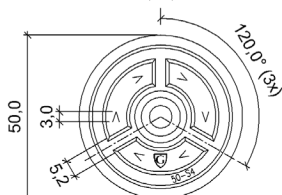
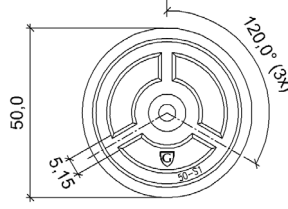

Fig. 10
SP 50-D,F,S Steel w asher



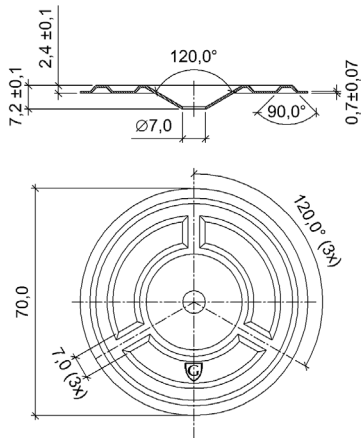

Fig. 11
SP 70-D,F,S Steel washer

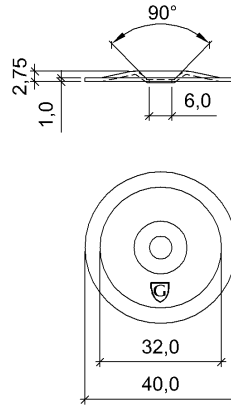

Fig. 12
SP 40-F,D,LBS Steel washer

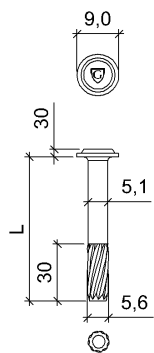

Fig. 13
BN 5.6 Concrete nail

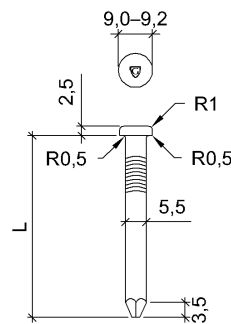

Fig. 14
BNRF 5.5 Stainless concrete nail

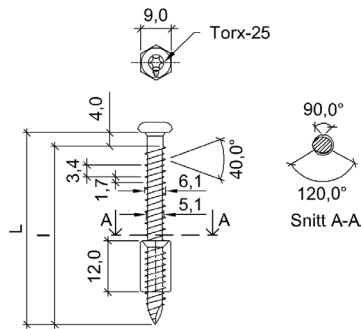

Fig. 15
ACS-6.1 Adjustable concrete screw (used together with tube washer HR-45 or HR-75)

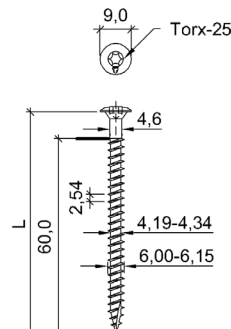

Fig. 16
HD 6.1 Screw for fixing in concrete, light weight concrete and wood

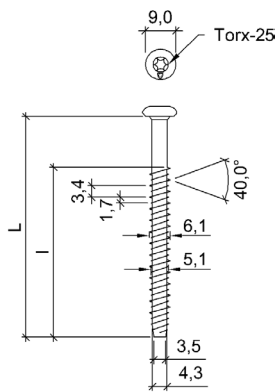

Fig. 17
CS 6.1 Concrete screw (with flat or sharp point)

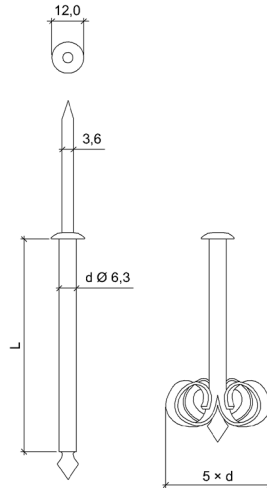

Fig. 18
GPR 6.3 Peel Rivet

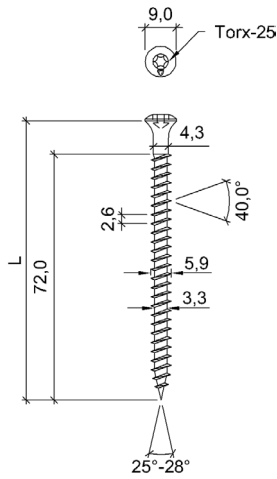

Fig. 19
LBS 6.0 Light weight concrete / wood screw

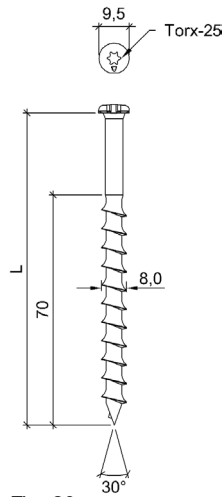

Fig. 20
LBS 8.0 Light weight concrete screw

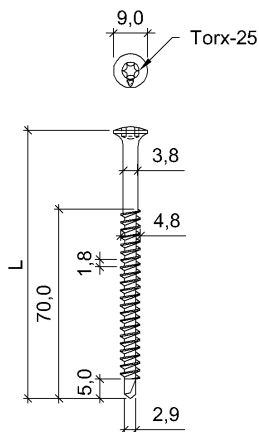

Fig. 21
BS 4.8 Screw for fixing in metal sheets

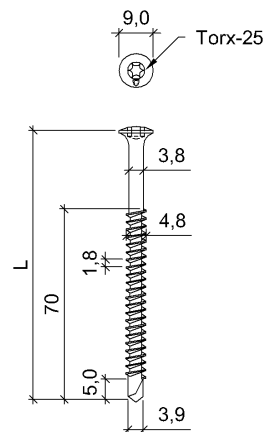

Fig. 22:
BSHD 4.8 Screw for fixing in metal sheets (steel thickness $\geq 1,0\text{mm}$)

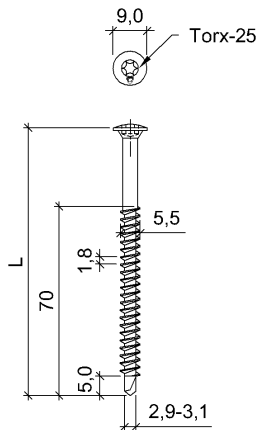

Fig. 23:
BS 5.5 Screw for fixing in metal sheets

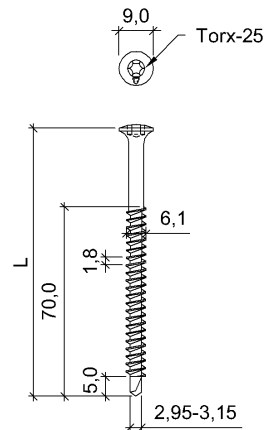

Fig. 24:
BS 6.1 Screw for fixing in metal sheets

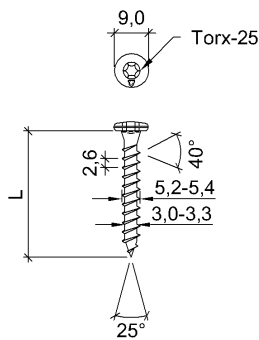

Fig. 25:
TS 5.2 Screw for fixing in wood

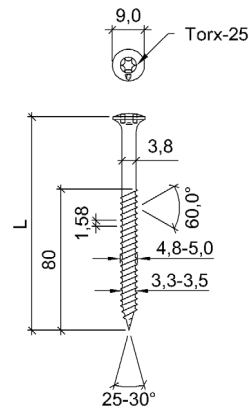

Fig. 26:
PS 4.8 Screw for fixing in metal sheets

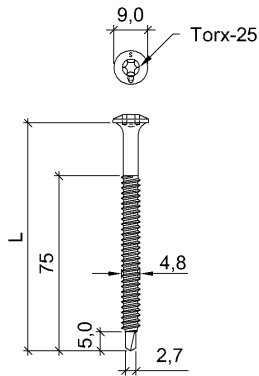

Fig. 27:
BSRF 4.8 Screw for fixing in metal sheets

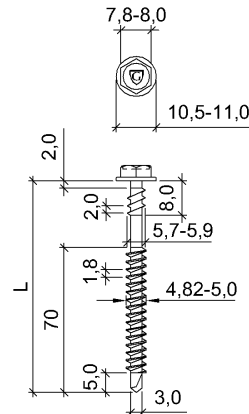

Fig. 28:
DBT(A)4.8 Screw for fixing in metal sheets

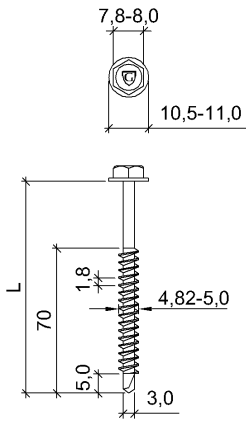

Fig. 29:
DB(A) 4.8 Screw for fixing in metal sheets

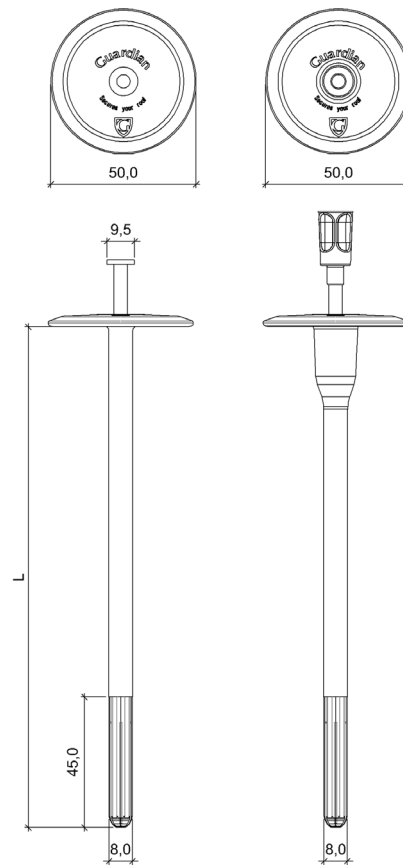

Fig. 30:
CPN-8 Concrete Plug std. version
CP-8 Cold bridge stop version

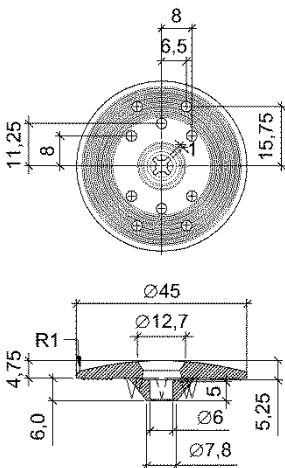

Fig 31:
Tube washer PP 45 with barbes

Performance of Guardian Fastening system on different substrates

Characteristic values are calculated from the following formula:

$$\alpha(x_m - k \cdot s)$$

where: α = Corr. factor for tested substrate spec. compared with nominal substrate spec.

x_m = mean axial pullout load for 10 specimens

$k = 1,92$ (according to Table D1 in EN-1990:2002)

s = standard deviation

Table 2: Profiled metal decking substrate ¹⁾

Fastener	Substrate	Washer ³⁾	Characteristic values of axial load resistance (kN)	Durability Resistance to unwinding ETAG 006 cl. 5.3.7 D.2.3, D.3.1, D.3.2 and cl. 5.3.4 D.2.2
GUARDIAN PS 4.8	Steel 0,70mm	SP 50	1,31	Approved
GUARDIAN PS 4.8	Steel 0,75mm	SP 50	1,52	Approved
GUARDIAN PS 4.8	Steel 1,00mm	SP 50	1,94	Approved
GUARDIAN BS 4.8	Steel 0,70mm	SP 50	1,17	Approved
GUARDIAN BS 4.8	Steel 0,75mm	SP 50	1,45	Approved
GUARDIAN BS 4.8	Steel 0,80mm	SP 50	1,54	Approved
GUARDIAN BSHD 4.8	Steel 1,00mm	SP 50	1,65	Approved
GUARDIAN BSHD 4.8	Steel 1,25mm	SP 50	2,10	Approved
GUARDIAN BS 5.5	Steel 0,72mm ²⁾	SP 50	1,74	Approved
GUARDIAN BS 6.1	Steel 0,60mm	Sleeve R 45	1,56	Approved
GUARDIAN BS 6.1	Steel 0,70mm	SP 50	1,78	Approved
GUARDIAN BS 6.1	Steel 0,75mm	SP 50	1,98	Approved
GUARDIAN BS 6.1	Steel 1,00mm	SP 50	2,77	Approved
GUARDIAN DBT 4.8	Steel 0,70mm	SPA 8240	1,17	Approved
GUARDIAN DBT 4.8	Steel 0,75mm	SPA 8240	1,41	Approved
GUARDIAN DBT 4.8	Steel 0,80mm	SPA 8240	1,52	Approved
GUARDIAN GPR 6.3	Steel 0,50mm	SP 50	1,19	Approved

¹⁾ Steel sheets, galvanized, min S280 according to EN 10147

²⁾ Steel sheets, galvanized, yield strength 320 MPa

³⁾ Obtained value from the axial load test in metal decking substrates, table 2, and the pullover test, table 6, of washers is compared and the lowest of the two gives the characteristic value for the fastener / sleeve, washer combination of the application.

Table 3: Concrete substrate ⁴⁾

Fastener	Substrate	Washer	Characteristic values of axial load resistance (kN)	Durability Resistance to unwinding ETAG 006 cl. 5.3.7 D.2.3, D.3.1, D.3.2 and cl. 5.3.4 D.2.2
GUARDIAN CS 6.1 / ACS-6.1	C25-C30	SP 50	4,28	Approved
GUARDIAN BNRF 5.5	C25-C30		1,79	Approved
GUARDIAN BN 5.6	C25-C30	SP 50	1,92	Approved
GUARDIAN CP & CPN (Polypropylene)	C25-C30	-	1,57	Approved
GUARDIAN HD 6.1	C25-C30	SP 50	4,83	Approved

⁴⁾ See clause 4,3 regarding hole diameter and drill depth

Table 4: Light weight concrete substrate ⁵⁾

Fastener	Substrate	Washer	Characteristic values of axial load resistance (kN)	Durability Resistance to unwinding ETAG 006 cl. 5.3.7 D.2.3, D.3.1, D.3.2 and cl. 5.3.4 D.2.2
GUARDIAN LBS 6.0	Ytong TM Density 600 kg/m ³	SP 50	2,07	Approved
GUARDIAN LBS 8.0	Density 450 kg/m ³	SP-40-LBS	0,93	Approved
GUARDIAN LBS 8.0	Density 550 kg/m ³	SP-40-LBS	1,44	Approved
GUARDIAN HD 6.1	Density 600 kg/m ³	SP 50	1,36	Approved

⁵⁾ Autoclaved aerated concrete units according to EN 771-4

Table 5: Wood substrate

Fastener	Substrate	Washer	Characteristic values of axial load resistance (kN)	Durability Resistance to unwinding ETAG 006 cl. 5.3.7 D.2.3, D.3.1, D.3.2 and cl. 5.3.4 D.2.2
GUARDIAN HD 6.1	18 mm OSB/3 ⁶⁾		1,36	Approved
GUARDIAN HD 6.1	18 mm multilayer wood deck		2,37	Approved
GUARDIAN HD 6.1	18 mm wood deck underlayment		1,94	Approved
GUARDIAN TS5.2	17mm softwood Class G4-2	SP 50	1,28	Approved
GUARDIAN TS5.2	23mm softwood Class G4-2	SP 50	1,90	Approved
GUARDIAN TS5.2	18 mm OSB/3 ⁶⁾	SP 50	1,35	Approved
GUARDIAN TS5.2	18 mm chipboard	SP 50	1,18	Approved
GUARDIAN TS5.2	18 mm multilayer wood deck	SP 50	1,89	Approved
GUARDIAN TS5.2	18 mm wood deck underlayment	SP 50	1,94	Approved
GUARDIAN LBS 6.0	18 mm OSB/3 ⁶⁾	SP 50	1,40	Approved
GUARDIAN LBS 6.0	23mm softwood Class G4-2	SP 50	2,00	Approved

⁶⁾ OSB board type 3 according to EN 300

Table 6**Pullover test of washer**

Fastener	Washer	Characteristic values of axial load resistance (kN)	Durability Resistance to unwinding ETAG 006 cl. 5.3.7 D.2.3, D.3.1, D.3.2 and cl. 5.3.4 D.2.2
GUARDIAN BS 4.8	SP- 50-F/S/D	4,83	Approved
GUARDIAN BS 4.8	SPB- 50-F/S/D	4,83	Approved
GUARDIAN BS 4.8	SP-70-S/D	2,88	Approved
GUARDIAN BS 4.8	Sleeve R(P)45, RB(P)48, RBS(P)50, R(P)75	1,58	Approved
GUARDIAN BS 4.8	TB(P) 8040	2,52	Approved
GUARDIAN BS 4.8	PP45	2,50	Approved
GUARDIAN ACS-6.1	Sleeve HR45, HR75	1,54	Approved
GUARDIAN BS 6.1	SPC80-F-4 CT Centrix tube washer	3,17	Approved
GUARDIAN BS 5.5	SPCP-80	2,48	Approved
GUARDIAN BS 5.5	SPA 8240-D/F/S	5,30	Approved
GUARDIAN TS 5,2	SP-40 – F/D/	3,88	Approved
GUARDIAN LBS 8	SP-40-LBS	4,29	Approved
GUARDIAN DBT 4,8	SPA 8040	5,00	Approved

Obtained values from the axial load test in different substrates (table 2 - 5) and the pullover test (table 6) of washers/sleeves are compared and the lowest of the two gives the characteristic value for the fastener / sleeve, washer combination of the application.